

NOTICE TO INSTALLER: Instructions must remain with installation.

SECTION: 6.10.079

"QUALITY PUMPS SINCE 1939"



FM1613
0403
Supersedes
1102

Product information presented here reflects conditions at time of publication. Consult factory regarding discrepancies or inconsistencies.

MAIL TO: P.O. BOX 16347 • Louisville, KY 40256-0347
SHIP TO: 3649 Cane Run Road • Louisville, KY 40211-1961
(502) 778-2731 • 1 (800) 928-PUMP • FAX (502) 774-3624

visit our web site:
<http://www.zoeller.com>

THE aquanot[®] Series by ZOELLER

MODELS 580 & 585

BATTERY BACKUP PEDESTAL SUMP PUMP

PREINSTALLATION CHECKLIST

1. **Inspect your pump.** Occasionally, products are damaged during shipment. If the unit or any of the parts are damaged, contact your dealer before using.
2. **Read all the installation instructions** regarding installing and start up. Retain for future reference.

▲ WARNING

SEE BELOW FOR LIST OF WARNINGS

- | | |
|---|--|
| <ol style="list-style-type: none"> 1. Testing for Ground. As a safety measure each electrical outlet should be checked for ground using an Underwriters Laboratory listed circuit analyzer, which will indicate if the power, neutral and ground wires are correctly connected to your outlet. If they are not, call a qualified licensed electrician. 2. For your protection always disconnect the power supply from its power source before handling the components of your DC backup pump or the primary pump. 3. Installation and checking of electrical circuits and hardware should be performed by a qualified, licensed electrician. | <ol style="list-style-type: none"> 4. All electrical and safety codes must be followed in addition to the National Electrical Code and all applicable local codes. 5.  It is the owner's responsibility to check the battery and battery connection at least once a month. Batteries contain acid and caution must be taken when handling. 6. Risk of electric shock - These pumps have not been investigated for use in swimming pool areas. |
|---|--|

▲ CAUTION

SEE BELOW FOR LIST OF CAUTIONS

- | | |
|--|--|
| <ol style="list-style-type: none"> 1. Make sure there is a properly grounded 115V receptacle available. Do not use primary pump circuit. The location must be within 6' of the control box and battery. The power supply for your DC control system plugs directly into the 115V outlet. DO NOT USE AN EXTENSION CORD. 2. Make sure the 115V electrical supply circuit is equipped with fuses or circuit breakers of proper capacity. 3. DC emergency pumps are designed for handling clear water. Do <u>not</u> use in septic tanks to pump effluent or sewage pits to pump sewage. 4. Repair and service of your DC backup system should be performed by an authorized service station. | <ol style="list-style-type: none"> 5. The installation of DC automatic backup pumps requires the use of a variable level float switch for operation. It is the responsibility of the installing party, to ensure that the float will not hang up on the pump apparatus or pit <u>peculiarities</u> and is secured so the pump will turn "on" and "off". It is recommended that the pit be 18" in diameter or larger to accommodate both a primary and a DC backup pump. |
|--|--|

REFER TO WARRANTY ON PAGE 2.

Limited Warranty

Zoeller Pump Company warrants, to the purchaser and subsequent owner during the warranty period, every new Zoeller Pump Company product to be free from defects in material and workmanship under normal use and service, when properly installed, used and maintained, for a period of one year from date of installation or 18 months from date of manufacturer, whichever comes first. Parts that fail, (within one year of installation or 18 months from date of manufacturer, whichever comes first) that inspections determine to be defective in material or workmanship, will be repaired, replaced or remanufactured at Zoeller Pump Company's option, provided however, that by so doing we will not be obligated to replace an entire assembly, the entire mechanism or the complete unit. No allowance will be made for shipping charges, damages, labor or other charges that may occur due to product failure, repair or replacement.

This warranty does not apply to any material that has been disassembled without prior approval of Zoeller Pump Company, subjected to misuse, misapplication, neglect, alteration, accident or act of God; that has not been installed, operated or maintained in accordance with Zoeller Pump Company installation instructions; that has been exposed to but not limited to the following: sand, gravel, cement, mud, tar, hydrocarbons or hydrocarbon derivatives (oil, gasoline, solvents, etc), wash towels or feminine sanitary products, etc. or other abrasive or corrosive substances. This warranty is in lieu of all other warranties

expressed or implied; and we do not authorize any representative or other person to assume for us any other liability in connection with our products.

Contact Zoeller Pump Company, 3649 Cane Run Road, Louisville, Kentucky 40211-1961, Attention: Customer Service Department to obtain any needed repair or replacement of part(s) or additional information pertaining to our warranty.

ZOELLER PUMP COMPANY EXPRESSLY DISCLAIMS LIABILITY FOR SPECIAL, CONSEQUENTIAL OR INCIDENTAL DAMAGES OR BREACH OF EXPRESSED OR IMPLIED WARRANTY; AND ANY IMPLIED WARRANTY OF FITNESS FOR A PARTICULAR PURPOSE AND OF MERCHANTABILITY SHALL BE LIMITED TO THE DURATION OF THE EXPRESSED WARRANTY.

Some states do not allow limitations on the duration of an implied warranty, so the above limitation may not apply to you. Some states do not allow the exclusion or limitation of incidental or consequential damages, so the above limitation or exclusion may not apply to you.

This warranty gives you specific legal rights and you may also have other rights which vary from state to state.

Note: The purchase of an Aquanot Battery from Zoeller Pump Company will extend the Limited Warranty to three years from date of installation.

Note: Three year limited warranty valid only when a complete system is purchased and used as a backup to a primary dewatering system. A complete system includes a Model 580 or 585 Aquanot Pump, Monitor/Charger, and an Aquanot Battery.

Carbon Monoxide Detectors

Whether you have an Aquanot Battery Backup Sump Pump System, or a competitive brand, all use batteries that give off gaseous by-products when charging. Some of these by-products can produce a rotten egg odor. Also, some of these by-products can cause a CO detector to falsely activate. In order to help prevent false activation, Zoeller recommends moving the battery as far apart from the CO detector as possible or, if necessary, vent the battery to the exterior. Zoeller provides the previous statements only as guidelines to help prevent false activation of the CO detector. In no way are they meant to supersede the instructions that accompany the detector nor do they supersede advice from the CO detector manufacturer.

If the audible alarm associated with your CO detector is activated, we recommend the following actions:

- 1) Take immediate action for personal safety as recommended in the CO detector literature.
- 2) Contact the appropriate agency to determine if the CO is being produced by your furnace, water heater, or any other device which uses natural gas.
- 3) If you are certain that no CO is being produced, then a charging battery may be producing gaseous by-products which are causing the CO detector to activate. Contact the manufacturer of the CO detector, and ask for recommendations as to what can be done to prevent the alarm activation.

Ten Helpful Hints For Easy Installation

1. Remove all debris from pit before installation.
2. Use a deep cycle battery only. Refer to battery descriptions on page 6.
3. Be sure the pump is on a firm, level surface.
4. Install a serviceable check valve in the discharge line.
5. Test the unit immediately after installation. Refer to STEP 6.
6. The battery & charger should be placed on a shelf.
7. Check float On/Off levels per STEP 2 of instructions.
8. Apply grease to the Positive and Negative terminals of the battery to prevent corrosion.
9. Check the battery water level once a month and add distilled water as necessary.
10. Obtain model number, date code and installation instructions before calling factory.

Do's And Don't's For Installing A Unit

1. **DO** read all installation material with the pump and charger.
2. **DO** inspect unit for any visible damage caused by shipping. Contact dealer if unit appears to be damaged.
3. **DO** clean all debris from the pit.
4. **DO** always disconnect pump from power source before handling. **DO** always connect to a separately protected and properly grounded ground fault protected circuit. **DO NOT** ever cut, splice or damage power cord. **DO NOT** carry or lift pump by its power cord. **DO NOT** use an extension cord with the Aquanot. **DO NOT** lengthen battery/pump leads.
5. **DO** install union check valve (see step 3) in the discharge line. **DO NOT** use a discharge pipe smaller than the recommended pump discharge sizes.
6. **DO** test pump immediately after installation to be sure that the system is working properly.
7. **DO** review all applicable local and national codes and verify that the installation conforms to each of them.

Performance Characteristics

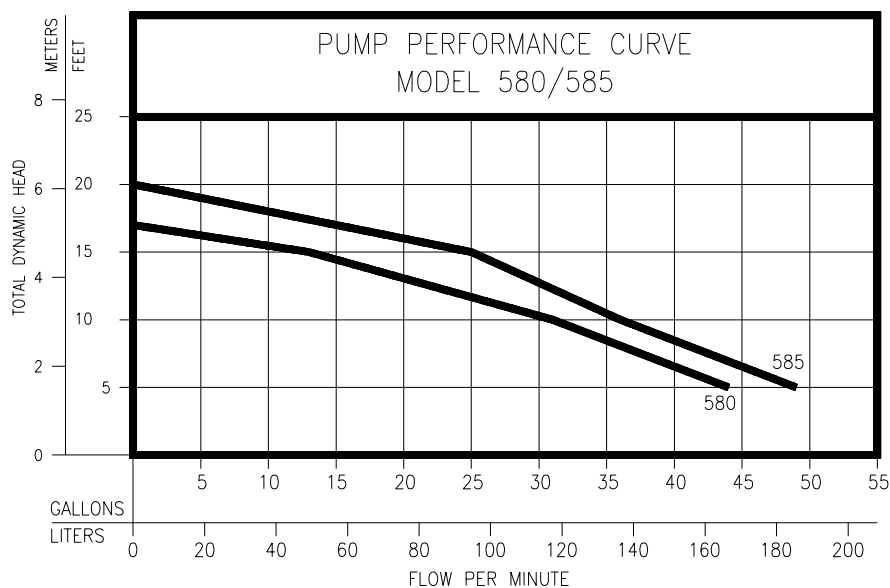

TOTAL DYNAMIC HEAD/FLOW PER MINUTE
EFFLUENT AND DEWATERING

MODEL		585	
Feet	Meters	Gal.	Liters
5	1.5	49	186
10	3.1	36	136
15	4.6	25	95
Shut-off Head:		20 ft.(6.1m)	

MODEL		580	
Feet	Meters	Gal.	Liters
5	1.5	44	167
10	3.1	31	117
15	4.6	13	49
Shut-off Head:		17 ft.(5.2m)	

011922A

011922B

Note: Aquanot II (Model 585) data was developed with the charger supplying DC power to the pump.

STEP 1

Placement of the Pump in the Pit

Note: If your pit has a cover, then it will have to be modified to accept the Aquanot.

- 1.1) Inspect the pit for debris and clean as necessary
- 1.2) Place the pump in the pit making certain that it is on a stable level surface. Refer to Figure 1.1.

IMPORTANT: If this pump is to be used as a backup to your primary pump, then make certain that there is no interference between the two pumps.

The motor is not watertight. It should **NEVER** be below floor level.

If necessary, bricks or similar materials, can be placed under the Aquanot.

▲ NOTICE This product is meant to be used as a battery backup pump to your primary pump only. Consult factory for advice before installing this unit as a primary pump.

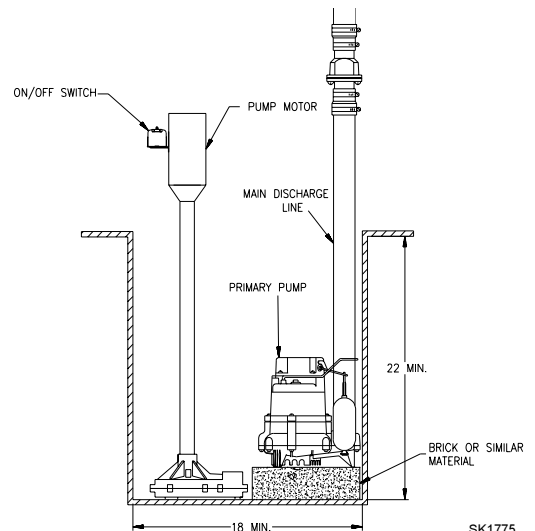

Figure 1.1

STEP 2

Float Stop Adjustment

- 2.1) With the pump in the pit, measure the desired float stop on/off positions as shown in Fig. 2.1. These two dimensions will determine the on/off levels of the pump. The spacing between the upper and lower stops will determine the amount of water removed from the pit.

Note: It may be necessary to raise the float rod guide to adjust the stops to the dimensions determined in Step 2.1.

▲ CAUTION The float rod guide should **NEVER** be between the upper and lower stop.

- 2.2) Remove the pump from the pit and adjust the float stops as necessary. Tighten all screws.

Note: If a brick, or similar material has been used to raise the pump in the pit, it will be necessary to account for the thickness of the brick.

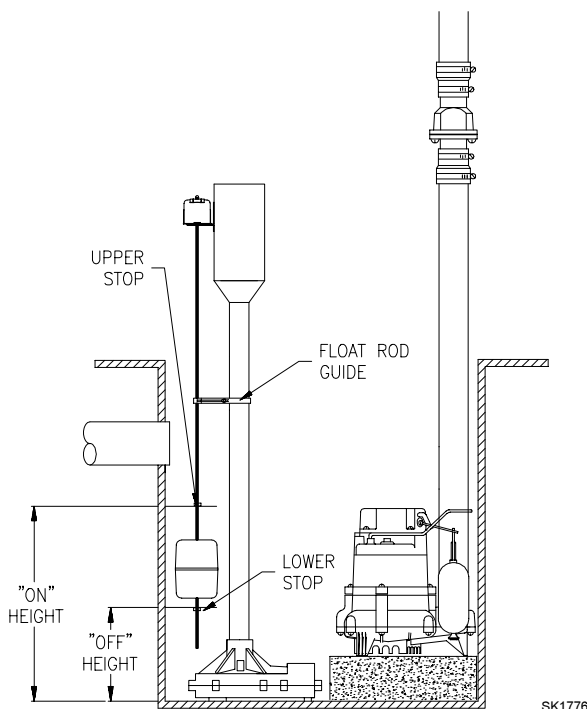

Figure 2.1

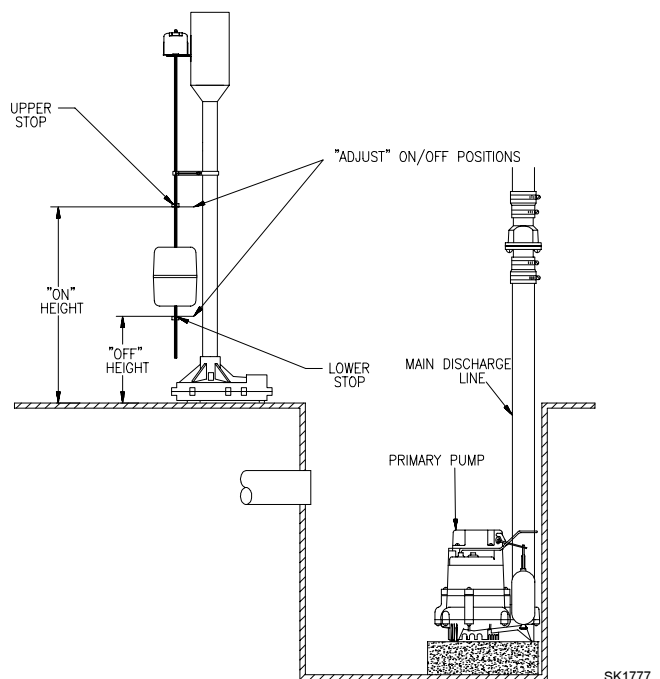

Figure 2.2

STEP 3

Installation of the Discharge Piping

3.1) Assemble the discharge pipe into the pump as shown in Figure 3.1.

IMPORTANT: In order for this installation to work properly, a check valve must be installed onto the discharge line.

P/N 30-0100
P/N 30-0101
P/N 30-0102
P/N 30-0103

} (Recommend the following Zoeller check valves:
Some local codes require union check with ball valve.

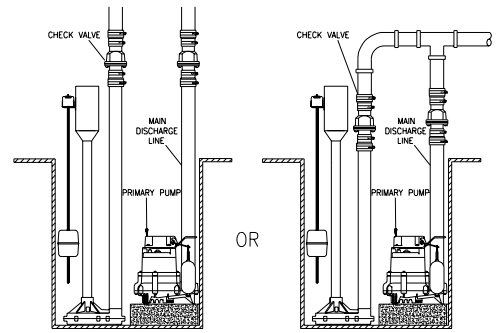

Figure 3.1

SK1778

STEP 4

Electrical Connections for Model 585

Note: This Step is for the Aquanot II (Model 585). Proceed to STEP 5 for installation of Aquanot I (Model 580).

4.1) Complete electrical connections as shown in Figure 4.1.

4.2) Proceed to STEP 6.

CAUTION Do not place battery or charger directly on ground. If the battery or charger must be placed directly on the ground, then place a piece of wood between the units and the ground. Do not put the charger on top of the battery.

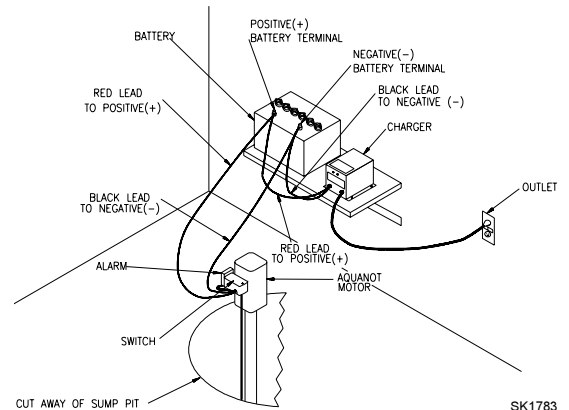

Figure 4.1

SK1783

STEP 5

Electrical Connections for Model 580

5.1) Complete the electrical connections as shown in Figure 5.1.

CAUTION Do not place battery or monitor directly on ground. If the battery or monitor must be placed directly on the ground, then place a piece of wood between the units and the ground. Do not put the battery monitor on top of the battery.

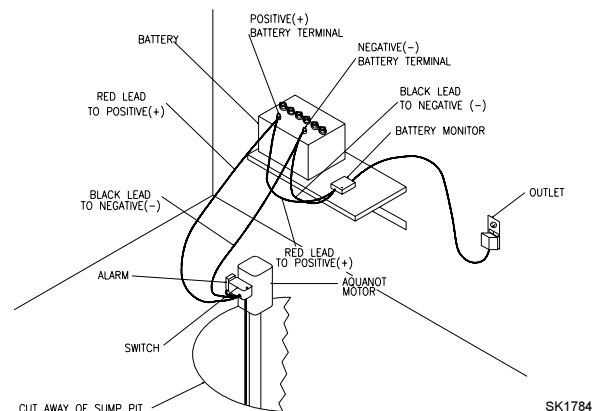

Figure 5.1

SK1784

STEP 6

Testing of Pump Operation

- 6.1) Unplug the primary pump so that it does not start.
- 6.2) Fill pit with water until the Aquanot starts.
- 6.3) Verify that the pump starts and stops at the desired on/off points.
- 6.4) Verify that there are no leaks in the discharge line.
- 6.5) If adjustment is necessary, raise or lower the appropriate stop(s) according to STEP 2.

IMPORTANT: Spacing between upper and lower stops determine amount of water removed from pit.

- 6.6) If the pump is not operating properly after following the above steps, refer to the Troubleshooting guide on page 7.
- 6.7) When finished testing plug primary pump back into AC receptacle.

Operation of the Aquanot Charger (Model 585 Only)

The charger automatically monitors and charges your battery. In the event of a power outage the pump will be powered by the battery. Once line power is restored, the charger will recharge the battery. If there is a failure of the primary pump, the charger will supply power to the pump through the battery if line power is present; otherwise, the battery will take over until the problem has been corrected.

The lights on the front panel of the charger indicate the state of system:

The red light: Indicates that AC line power is present.

The green light: Indicates that the battery is charged to 12V DC*.

During periods of extended power outage the charge on the battery may drop below 12V DC which would cause the green light to go out. This is normal. The green light will be illuminated once the charger restores the voltage level to 12V DC.

The yellow light: Indicates that the battery is charged above 8V DC.

If the yellow light is not illuminated, it indicates that the charge on the battery is below 8V DC. If the line power is out, the pump may have depleted the battery due to normal operation. If there has been no power outage and the primary pump is working properly, it may indicate that the battery is defective or that the controller is defective. Refer to the Troubleshooting guide on page 7 for further instructions.

If the Green and Yellow lights flash intermittently, refer to Section F in the Trouble Shooting Guide on page 7.

*Voltage is only one indicator of the state of the battery, and does not reflect the true condition of the battery. Use a hydrometer to more accurately determine the condition of the battery.

Operation of the Audible Alarm (All Models)

All Aquanot pump systems are equipped with an alarm which sounds when the pump is activated. The alarm will automatically silence when the pumping cycle is completed.

Activation of the audible alarm indicates that the primary pump has failed or line power to the primary pump is not present. Whenever the alarm is activated the primary pump and outlet should be inspected.

The On/Off switch, located on the side of the alarm enclosure, allows the audible alarm to be turned off, however, this practice is not recommended. Verify that the alarm switch is in the "on" position, by manually turning the pump "on".

The Aquanot Battery

There are millions of batteries manufactured each year, so it is impossible to guarantee consistent quality. A defective battery will never become fully charged and may damage the circuits of the charger. It is for this reason that Zoeller offers its own line of batteries. We offer both a Water/Acid Deep-Cycle Battery which can run the pump continuously for over 7½ hours, and an AGM battery, which will power the pump for over 3½ hours. These times are based on continuous pumping at 10' of static head. Actual times will vary depending on static head, volume of water entering the pit, and the condition of the battery.

Follow these recommendations:

- Use a B.C.I. size 27 deep-cycle battery, 175 minute reserve capacity, or larger.
- Do NOT use a "maintenance-free" battery unless it is Gel-filled or AGM battery.
- Replace your battery every 3 years.
- Do not let corrosion build up on the battery terminals.
- Do not place your battery on a concrete floor where it will discharge faster.
- To check specific gravity, follow the instructions on a hydrometer (not applicable for Gel or AGM batteries).

PROTECT YOUR WARRANTY:

- Water level in batteries must be checked once a month (not applicable for Gel or AGM batteries).

20-MODEL 580/585 COMPLETE PUMP

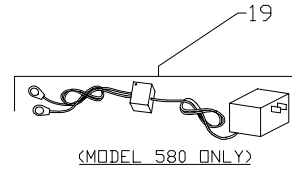
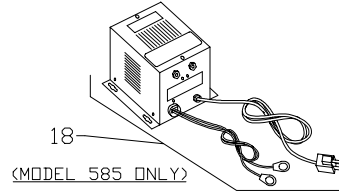
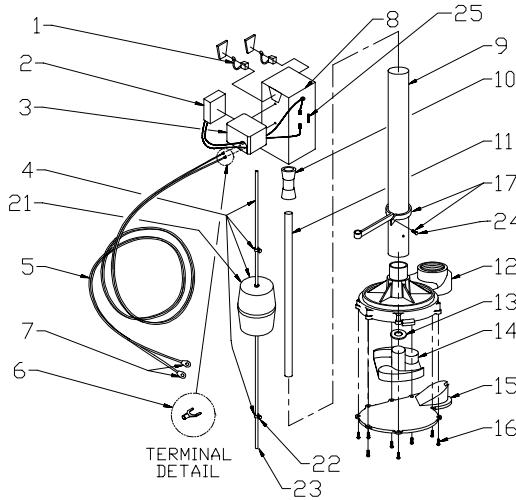

SK1786

Illustrated Parts Breakdown

REF. NO.	DESCRIPTION	QTY	MODELS:									
			580-A	580-B	580-C	580-D	585-A	585-B	585-C	585-D	585-E	
			1/98 to 8/98	9/98 to 1/00	2/00 to 09/00	10/00 to Present	1/98 to 5/98	6/98 to 8/98	9/98 to 1/00	2/00 to 09/00	10/00 to Present	
1	Motor Brushes	2	011882	011882	011882	013878	011882	011882	011882	011882	013878	
2	Pump Alarm	1	012485	012485	012485	012485	012485	012485	012485	012485	012485	
3	Pump Switch	1	011990	011990	012705	012705	011990	011990	011990	012705	012705	
4	Float Kit & Cable	1	012109	012109	012709	012709	012109	012109	012109	012709	012709	
5	Lead Wires	1	012401	012401	012401	012401	012401	012401	012401	012401	012401	
6	Terminal Spade	1	004442	004442	004442	004442	004442	004442	004442	004442	004442	
7	Terminal Ring	1	011939	011939	011939	011939	011939	011939	011939	011939	011939	
8	Pump Motor	1	013873	013873	013873	013873	013873	013873	013873	013873	013873	
9	Column	1	011942	011942	011942	011942	011942	011942	011942	011942	011942	
10	Adapter, Drive	1	011940	011940	011940	011940	011940	011940	011940	011940	011940	
11	Shaft	1	011944	011944	011944	011944	011944	011944	011944	011944	011944	
12	Head w/Brass Bearing	1	011947	012137	012137	012137	011947	011947	012137	012137	012137	
13	Washer, Thrust	1	002140	002140	002140	002140	002140	002140	002140	002140	002140	
14	Impeller	1	011945	011945	011945	011945	011945	011945	011945	011945	011945	
15	Base Plate	1	011948	012138	012138	012138	011948	011948	012138	012138	012138	
16	Screws	8	011949	012118	012118	012118	011949	012118	012118	012118	012118	
17	Guide, Float Rod	1	N/A	N/A	003903	003903	N/A	N/A	N/A	003903	003903	
18	Battery Charger (585 Only)	1	N/A	N/A	N/A	N/A	012309	012298	012298	012298	012298	
19	Battery Monitor (580 Only)	1	012484	012484	012484	012484	N/A	N/A	N/A	N/A	N/A	
20	Pump 580/585	1	585-0006	585-0006	585-0006	585-0006	585-0006	585-0006	585-0006	585-0006	585-0006	
21	Float	1	N/A	N/A	012707	012707	N/A	N/A	N/A	012707	012707	
22	Stop, Float	2	N/A	N/A	054085	054085	N/A	N/A	N/A	054085	054085	
23	Rod, Float	1	N/A	N/A	012706	012706	N/A	N/A	N/A	012706	012706	
24	Screws	1	N/A	N/A	003925	003925	N/A	N/A	N/A	003925	003925	
25	Fuse, 30 Amp	1	011927	012353	012353	012353	011927	012353	012353	012353	012353	



▲ WARNING Before servicing a pump, always shut off the main power breaker and then unplug the pump - making sure you are not standing in water and are wearing insulated protective sole shoes. Under flooded conditions, contact your local electric company or a qualified licensed electrician for disconnecting electrical service prior to pump removal.

If the following checklist does not solve the problem, consult Zoeller's Technical Service Department 1-(800) 928-7867 - Do not attempt to service or otherwise disassemble pump.

Troubleshooting Guide

Condition	Possible Cause	Remedy
A. PUMP WILL NOT START OR RUN.	Low voltage, blown fuse open circuit.	Have a qualified electrician check fuse and circuit.
	Impeller bound.	Replace fuse.
	Blown pump fuse.	
	Defective Switch	Contact factory.
	Motor or wiring shorted.	
B. PUMP STARTS TOO SOON.	Float "ON" point is adjusted too low.	Refer to STEP 2.
C. PUMP WILL NOT SHUT OFF.	Float is obstructed.	Inspect float operation and correct problem.
	Float "Off" point adjusted too low.	Adjust "Off" point. Refer to STEP 2.
	Faulty float switch.	Contact factory.
D. PUMP OPERATES BUT DELIVERS LITTLE OR NO WATER.	Debris around intake.	Clean area around intake.
	Blockage in discharge pipe.	Remove pipe and flush out debris.
	Low voltage.	Check condition of battery. Replace as necessary or recharge.
	Blown fuse, open circuit.	Have a qualified electrician check circuit.
	Incorrect float adjustment	Refer to STEP 2 for proper installation.
	Pump is air locked.	Drill 1/4" hole in discharge pipe below waterline.
	Vertical lift too high.	Change discharge piping or contact tech. service.
	Base plate is "loose" or corroded.	Remove pump from pit and tighten as necessary.
	Pump runs in reverse.	Make certain that the red(+) lead and black(-) leads go to the appropriate battery terminals.
	Damaged Impeller.	Contact factory.
E. RED LIGHT ON CHARGER (MODEL 585) IS OUT.	Resettable fuse tripped.	Reset fuse located on charger housing.
	Power outage.	Normal condition Red light will be illuminated once line power is restored.
	Defective controller or light burned out.	Contact factory.
F. GREEN & YELLOW LIGHTS FLASH INTERMITTENTLY		Check water level of battery, refill as necessary (Do not overfill).
		Defective battery. Replace as necessary.
	Positive & Negative battery leads are reversed.	Make certain that the positive (red) & negative (black) leads go to the proper battery terminals.
	Battery has a "Dead Short".	Replace battery. Battery has aged beyond its ability to chemically store electricity.
	Loose battery connections.	Tighten red and black battery leads.
	Corroded battery terminals.	Clean terminal as necessary. Apply grease to terminals to prevent future corrosion problems.
	Lights flash for approximately 4 seconds.	Normal condition. The lights indicate that the system is properly installed.
G. CONSTANTLY ADDING DISTILLED WATER TO BATTERY.	Defective battery.	Have battery inspected. The charger will overcharge a battery with a defective cell.
	Defective controller.	Contact factory.
H. ROTTEN EGG SMELL IN BASEMENT.	Charger is overcharging battery.	Have battery inspected. The charger will overcharge a battery with a defective cell.



<http://www.zoeller.com>

ZOELLER

PUMP CO.

MAIL TO: P.O. BOX 16347
Louisville, KY 40256-0347
SHIP TO: 3649 Cane Run Road
Louisville, KY 40211-1961
(502) 778-2731 • 1 (800) 928-PUMP
FAX (502) 774-3624

Manufacturers of . . .

"QUALITY PUMPS SINCE 1939"